



## 2 YD STATIONARY COMPACTOR

### SPECIFICATIONS

MFG Rating CU/YD	2
Wastec Rating CU/YD	1.55
Clear Top Opening (L" x W")	42.5" x 57.5"
Ram Face (H" x W")	26" x 60"
Ground Height	15.5"
Capacity Per Hour	119

### PERFORMANCE

Cycle Time (Seconds)	47
Normal Force lbs.	48,100
Maximum Force lbs.	56,600
Normal Ram Face Pressure PSI	28.1
Maximum Ram Face Pressure PSI	33.1
Ram Penetration	13.5"

### HYDRAULIC/ELECTRICAL

Motor HP	10
Control Voltage	120VAC
Pump GPM	11.5
Normal System Pressure PSI	1,800
Maximum System Pressure PSI	2,100
Cylinder Bore/Rod Diameter	6" / 4"
Stroke	56"
Hydraulic Tank-Capacity Gallons	25

### CONSTRUCTION

Charge Box Sides	1/4"
Exterior Vertical/Horizontal Formed V	7 Ga
Charge Box Floor	1/2"
Ram Face	1/2"
Ram Bottom	3/8"
Ram Top	1/4"
Breaker Bar Structural Angle	6" x 8" x 1"
Weight	5,410

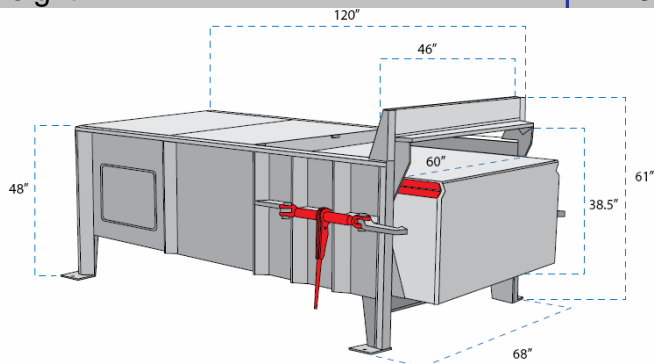

### MODEL KB - C2

*Built tough the 2 yard stationary units with 1/2" floor plate, 1/4" sides, and V channel construction perform under the most stringent requirements. Available heavy duty units perform with over 60,000 lbs. normal force.*

**KenBay**  
 PO Box 242  
 Mendham, NJ 07945  
 Phone: (973) 543-3200  
 Toll Free: (888) 353-6229  
 Fax: (973) 543-7606  
 www.KENBAY.com

